

Improved EA Tremolo Modification Instructions

Version 2007November15

Copyright 2007 JD Sleep

Permission refused for posting/serving this file from any site other than www.generalguitargadgets.com

Trademarks are property of their owners

This document outlines some modifications that can be done to this project.

Flashing LED Modification

The first modification is to install a flashing LED. The LED will flash in time with the tremolo speed which may be useful or at least neat to look at. The way this modification works is to replace R8 (15k) with a 10k resistor and an LED in series. It's as simple as that. The PCB includes extra pads to do this and R8 (10k) should be installed standing on-end. There are at least a couple ways to wire the flashing LED. One way is to have two LEDs on your box, one for the Bypass indicator and another for the speed rate as shown in this diagram:

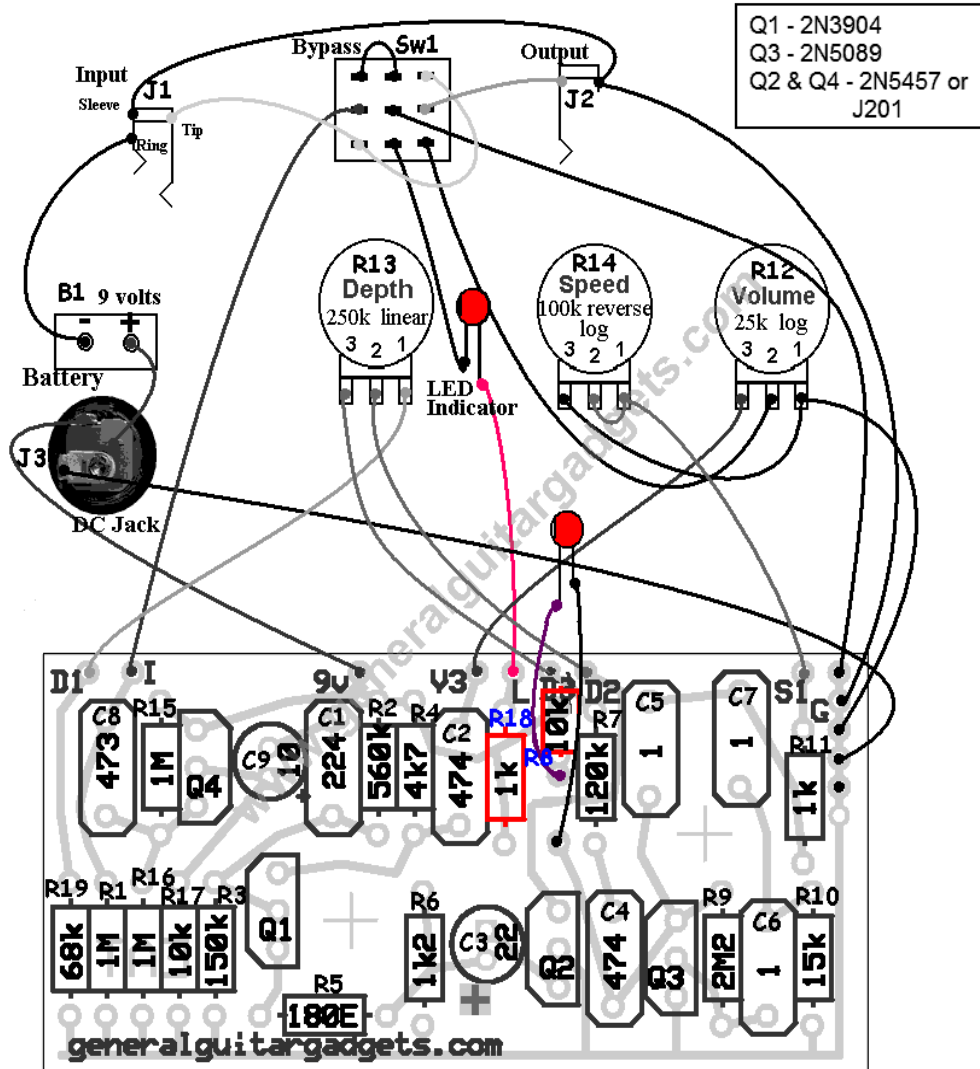

The additional LED will flash in time with the speed rate even when bypassed.

Improved EA Tremolo Modification Instructions

Version 2007November15

Copyright 2007 JD Sleep

Permission refused for posting/serving this file from any site other than www.generalguitargadgets.com

Trademarks are property of their owners

Another way to wire the flashing LED is to have a "dual-duty" LED that serves as true-bypass indicator and flashes at the speed rate. The following diagram illustrates how to wire to this configuration:

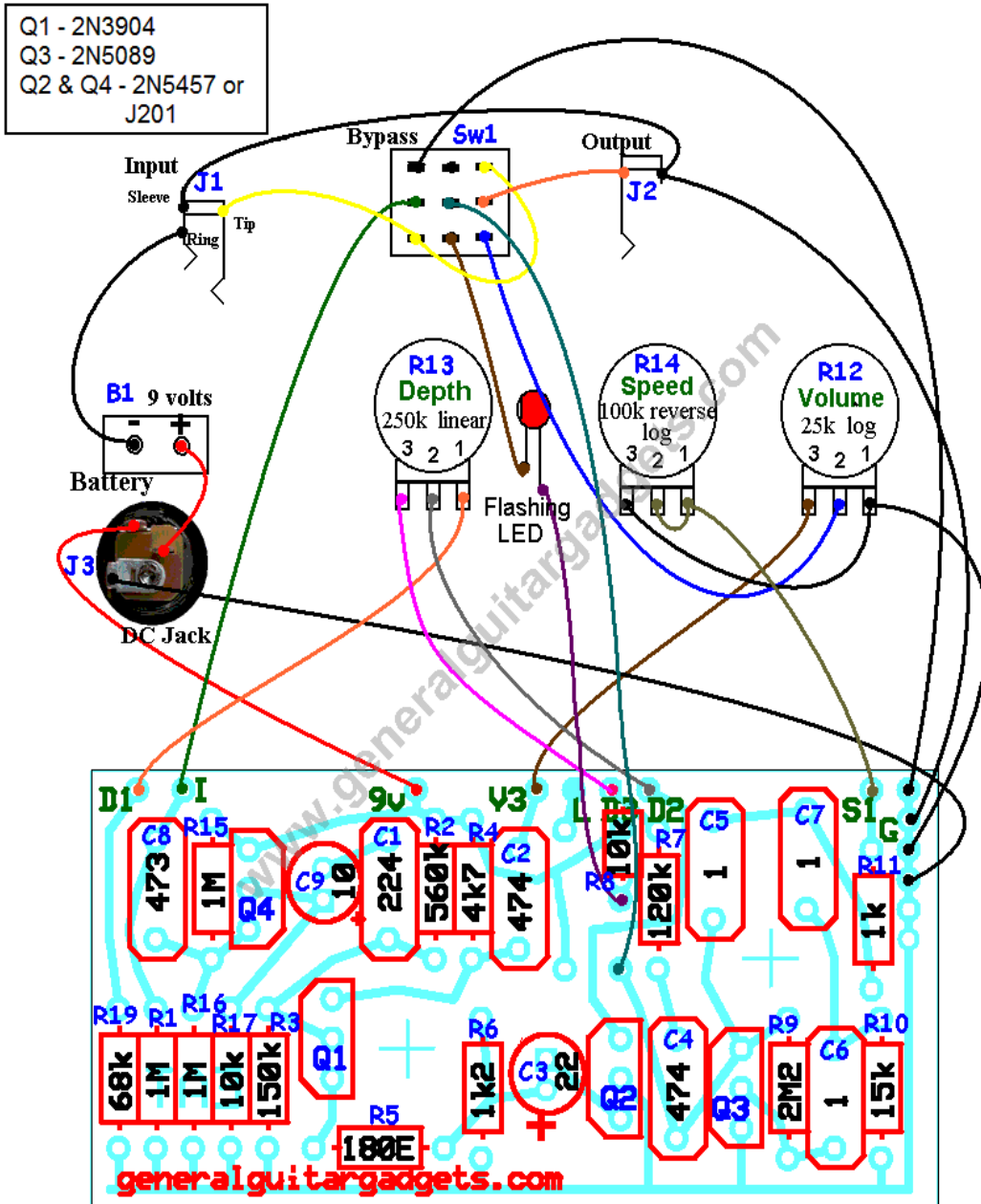

Improved EA Tremolo Modification Instructions

Version 2007November15

Copyright 2007 JD Sleep

Permission refused for posting/serving this file from any site other than www.generalguitargadgets.com

Trademarks are property of their owners

Booster Modification

The original article used a shunt switch to turn the tremolo on and off, shunting the LFO output to ground to kill the tremolo, leaving the "preamp" in the signal chain at all times. This method of switching the tremolo effect on and off has been replaced by true bypass on all the modern versions, as we have done in this project. But what is it that really makes this tremolo pedal sound so good? What makes this unit so much better than so many of the other tremolo pedals? We believe that it is not so much the section of the circuit that modulates the amplitude, but it is a **preamp with beautiful tone!** You'll appreciate what we mean by beautiful tone if you try this modification. All we do for this modification is to incorporate the original shunt switch back into the circuit and we have a dual-duty Booster(Preamp)-Tremolo Unit as it was originally intended. This modification is so simple it's ridiculous. Just add a SPST toggle switch wired as shown in the following diagram. One lug to the Depth control wiper and the other lug to any ground point.

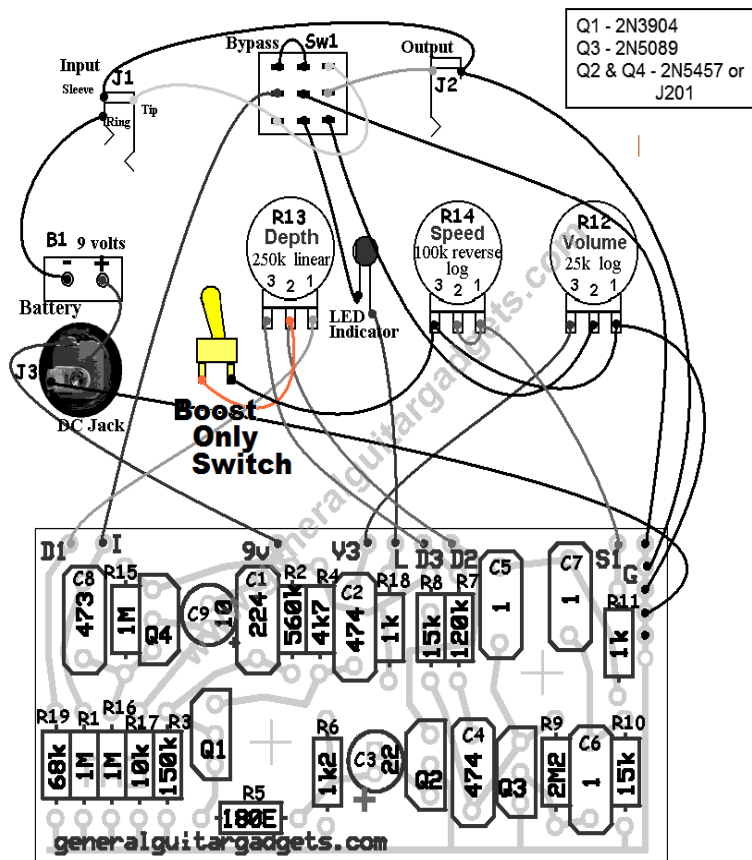

Note that we still retain the true bypass so that you can still take the pedal out of your



Improved EA Tremolo Modification Instructions

Version 2007November15

Copyright 2007 JD Sleep

Permission refused for posting/serving this file from any site other than www.generalguitargadgets.com

Trademarks are property of their owners

signal chain if you wish, but the extra switch just cuts the tremolo effect and lets you use the "preamp" section of the circuit as a really nice booster. The switch could be an additional footswitch if you are so inclined.

Comments and questions are welcome and can be sent to info@generalguitargadgets.com